



MLFB-Ordering data: **1LE1003-1BA22-2JA4**

Motor type: **1AV3112A**

Client order no.:

Item no.:

Order no.:

Consignment no.:

Offer no.:

Project:

Remarks:

U [V]	Δ/Y	f [Hz]	P [kW]	P [hp]	I [A]	n [1/min]	M [Nm]	NOM. EFF at ... load [%]			Power factor at ... load			I _A /I _N I _L /I _N	M _A /M _N T _f /T _N	M _k /M _N T _B /T _N	IE-CL
								4/4	3/4	2/4	4/4	3/4	2/4				
230	Δ	50	4.00	- / -	12.70	2945	13.0	88.1	89.1	88.7	0.90	0.88	0.81	8.2	1.8	3.5	IE3
400	Y	50	4.00	- / -	7.30	2945	13.0	88.1	89.1	88.7	0.90	0.88	0.81	8.2	1.8	3.5	IE3
460	Y	60	4.55	- / -	7.30	3545	12.0	87.5	88.1	87.3	0.90	0.87	0.81	8.5	2.0	3.7	IE2
460	Y	60	4.00	- / -	6.00	3560	10.0	88.5	88.2	86.6	0.88	0.84	0.76	10.3	2.5	4.5	IE3
IM B35 / IM 2001			FS 112 M		34 kg	IP55	IEC/EN 60034		IEC, DIN, ISO, VDE, EN								

Mechanical data			Terminal box	
Sound pressure level 50Hz/60Hz (load)	69 dB(A)	73 dB(A)	Terminal box position	top
Moment of inertia	0.012 kg m ²		Material of terminal box	Aluminium
Bearing DE NDE	6206 2Z C3	6206 2Z C3	Type of terminal box	TB1 F00
Bearing lifetime	40000 h		Contact screw thread	M4
Lubricants	Esso Unirex N3		Max. cross-sectional area	4.0 mm ²
Regreasing device	No		Cable diameter from ... to ...	11.0 mm - 21.0 mm
Grease nipple	- / -		Cable entry	2xM32x1,5
Type of bearing	Preloaded bearing DE		Cable gland	2 plugs
Condensate drainage holes	No		Special design (0)	
External earthing terminal				
Vibration severity grade	A			
Insulation	155(F) to 130(B)			
Duty type	S1			
Direction of rotation	bidirectional			
Frame material	aluminum			
Data of anti condensation heating	-/-			
Coating (paint finish)	Standard paint finish C2			
Color, paint shade	RAL7030			
Motor protection	(A) without (Standard)			
Method of cooling	IC411 - self ventilated, surface cooled			

Environmental conditions	
Ambient temperature	-20 °C - +40 °C
Altitude above sea level	1000 m

刀线管
 用文全
 图
 版
 号
 01
 02
 03
 04
 05
 06
 07
 08
 09
 10
 11
 12
 13
 14
 15
 16
 17
 18
 19
 20
 21
 22
 23
 24
 25
 26
 27
 28
 29
 30
 31
 32
 33
 34
 35
 36
 37
 38
 39
 40
 41
 42
 43
 44
 45
 46
 47
 48
 49
 50
 51
 52
 53
 54
 55
 56
 57
 58
 59
 60
 61
 62
 63
 64
 65
 66
 67
 68
 69
 70
 71
 72
 73
 74
 75
 76
 77
 78
 79
 80
 81
 82
 83
 84
 85
 86
 87
 88
 89
 90
 91
 92
 93
 94
 95
 96
 97
 98
 99
 100

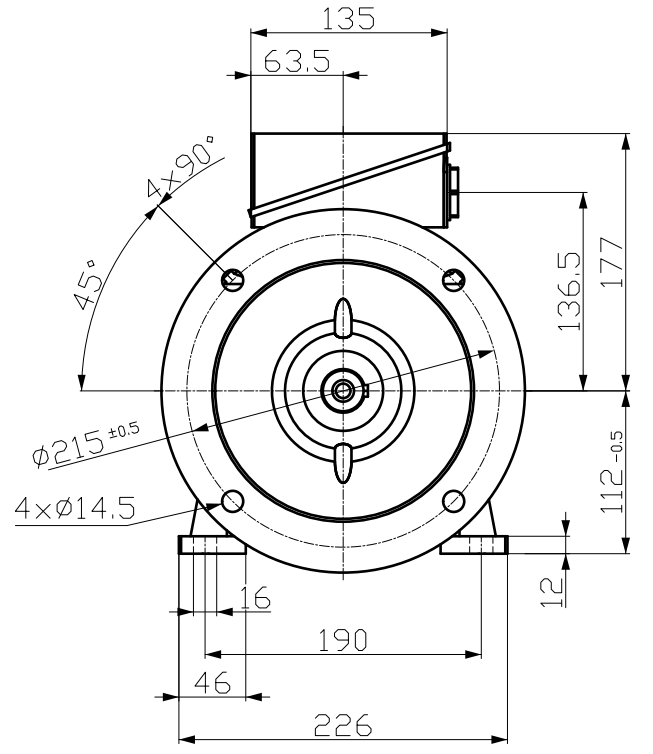
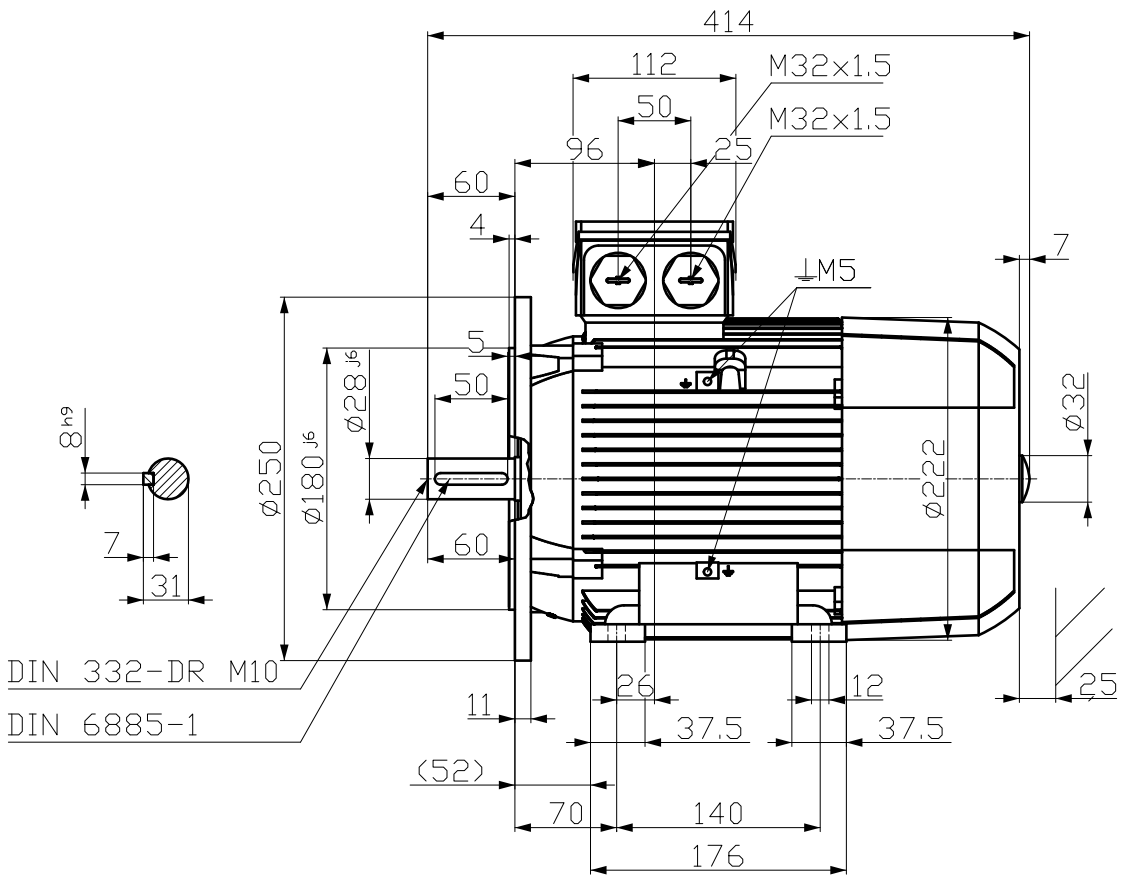

Tolerance	Surface	Material	Weight	Scale
FSÖFEHÖÖÖÖÖÖ	Author	ÖS	É	{ }
É	Creator	ÖVS	ÖS	
	Approval	TÖS		
	Department			
	Change Order	MFB		Doc Type
	Doc. State	FFÖJÖ		Paper Size
	Revision	Index	RS	1st Language
				2nd Language
© Siemens AG	2018	Project No	É	Sheet
		Ref No	É	F of F

SIEMENS