



MLFB-Ordering data: **1LE1503-1BB22-2AA4-Z**  
F74

Motor type: **1CV3112B**

Client order no.:

Item no.:

Order no.:

Consignment no.:

Offer no.:

Project:

Remarks:

U [V]	Δ/Y	f [Hz]	P [kW]	P [hp]	I [A]	n [1/min]	M [Nm]	NOM. EFF at ... load [%]			Power factor at ... load			I <sub>A</sub> /I <sub>N</sub> I/I <sub>N</sub>	M <sub>A</sub> /M <sub>N</sub> T <sub>f</sub> /T <sub>N</sub>	M <sub>k</sub> /M <sub>N</sub> T <sub>B</sub> /T <sub>N</sub>	IE-CL
								4/4	3/4	2/4	4/4	3/4	2/4				
230	Δ	50	4.00	- / -	13.80	1460	26.0	88.6	89.2	88.6	0.82	0.76	0.65	7.1	2.4	3.7	IE3
400	Y	50	4.00	- / -	7.90	1460	26.0	88.6	89.2	88.6	0.82	0.76	0.65	7.1	2.4	3.7	IE3
460	Y	60	4.55	- / -	7.70	1760	25.0	89.5	90.0	89.3	0.83	0.78	0.67	7.3	2.5	3.8	IE3
460	Y	60		- / -	6.50	1770	20.0	89.5	89.4	87.7	0.80	0.73	0.61	8.2	2.9	4.3	IE3
IM B3 / IM 1001		FS 112 M		46 kg		IP55		IEC/EN 60034		IEC, DIN, ISO, VDE, EN							

Mechanical data			Terminal box	
Sound pressure level 50Hz/60Hz (load)	58 dB(A) <sup>1)</sup>	62 dB(A) <sup>1)</sup>	Terminal box position	top
Moment of inertia	0.017 kg m <sup>2</sup>		Material of terminal box	cast iron
Bearing DE   NDE	6206 2Z C3	6206 2Z C3	Type of terminal box	TB1 F01
Bearing lifetime	40000 h		Contact screw thread	M4
Lubricants	Unirex N3		Max. cross-sectional area	4.0 mm <sup>2</sup>
Regreasing device	No		Cable diameter from ... to ...	11.0 mm - 21.0 mm
Grease nipple	- / -		Cable entry	2xM32x1,5
Type of bearing	Preloaded bearing DE		Cable gland	2 plugs
Condensate drainage holes	Yes (standard)		<div style="border: 1px solid black; padding: 5px; text-align: center;"> <b>Special design (1)</b>                      F74 Sheet steel fan cowl                 </div>	
External earthing terminal				
Vibration severity grade	A			
Insulation	155(F) to 130(B)			
Duty type	S1			
Direction of rotation	bidirectional			
Frame material	cast iron			
Data of anti condensation heating	- / -			
Coating (paint finish)	Standard paint finish C2			
Color, paint shade	RAL7030			
Motor protection	(A) without (Standard)			
Method of cooling	IC411 - self ventilated, surface cooled			

Environmental conditions	
Ambient temperature	-20 °C - +40 °C
Altitude above sea level	1000 m

Notes	
I <sub>A</sub> /I <sub>N</sub> = locked rotor current / current nominal	M <sub>k</sub> /M <sub>N</sub> = break down torque / nominal torque
M <sub>k</sub> /M <sub>N</sub> = locked rotor torque / torque nominal	1) Value is valid only for DOL operation with motor design IC411

刀线管  
 用文全  
 图  
 积  
 01  
 02  
 03  
 04  
 05  
 06  
 07  
 08  
 09  
 10  
 11  
 12  
 13  
 14  
 15  
 16  
 17  
 18  
 19  
 20  
 21  
 22  
 23  
 24  
 25  
 26  
 27  
 28  
 29  
 30  
 31  
 32  
 33  
 34  
 35  
 36  
 37  
 38  
 39  
 40  
 41  
 42  
 43  
 44  
 45  
 46  
 47  
 48  
 49  
 50  
 51  
 52  
 53  
 54  
 55  
 56  
 57  
 58  
 59  
 60  
 61  
 62  
 63  
 64  
 65  
 66  
 67  
 68  
 69  
 70  
 71  
 72  
 73  
 74  
 75  
 76  
 77  
 78  
 79  
 80  
 81  
 82  
 83  
 84  
 85  
 86  
 87  
 88  
 89  
 90  
 91  
 92  
 93  
 94  
 95  
 96  
 97  
 98  
 99  
 100

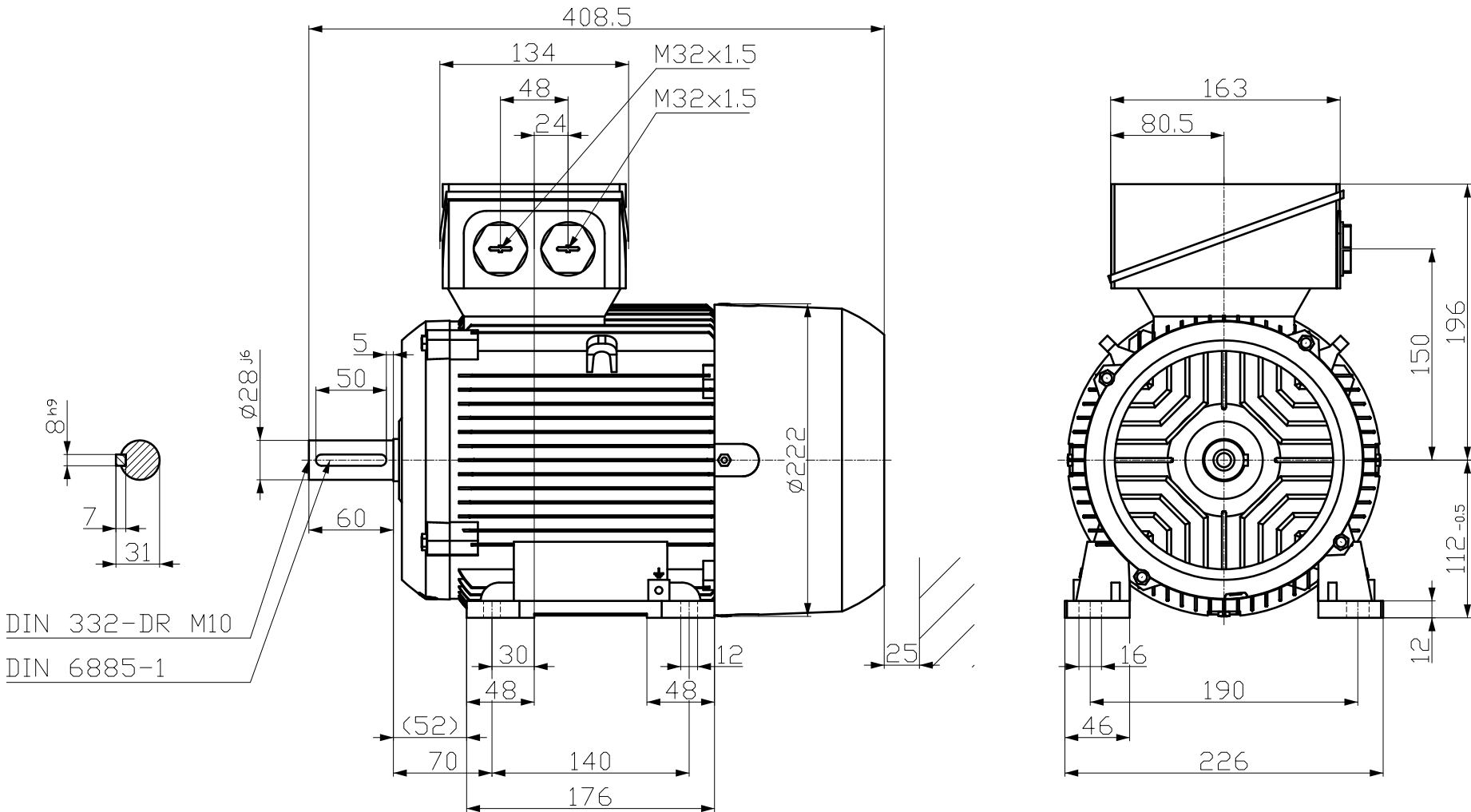

Tolerance	Surface	Material	Weight	Scale
F50F1			È	{ }
Author	Creator	ÖVS	Ö	
Approval	Department	T	T	
Change Order	Doc. State	MLFB	Doc. Type	
Doc. State	Revision	Item No	Paper Size	CH
Revision	Index	Doc. No	1st Language	^
Project No	RS	Ref. No	2nd Language	â
© Siemens AG 2018	È	È	Sheet	F of F

SIEMENS